

NEW

Medium Static Pressure Duct Compact & Comfort

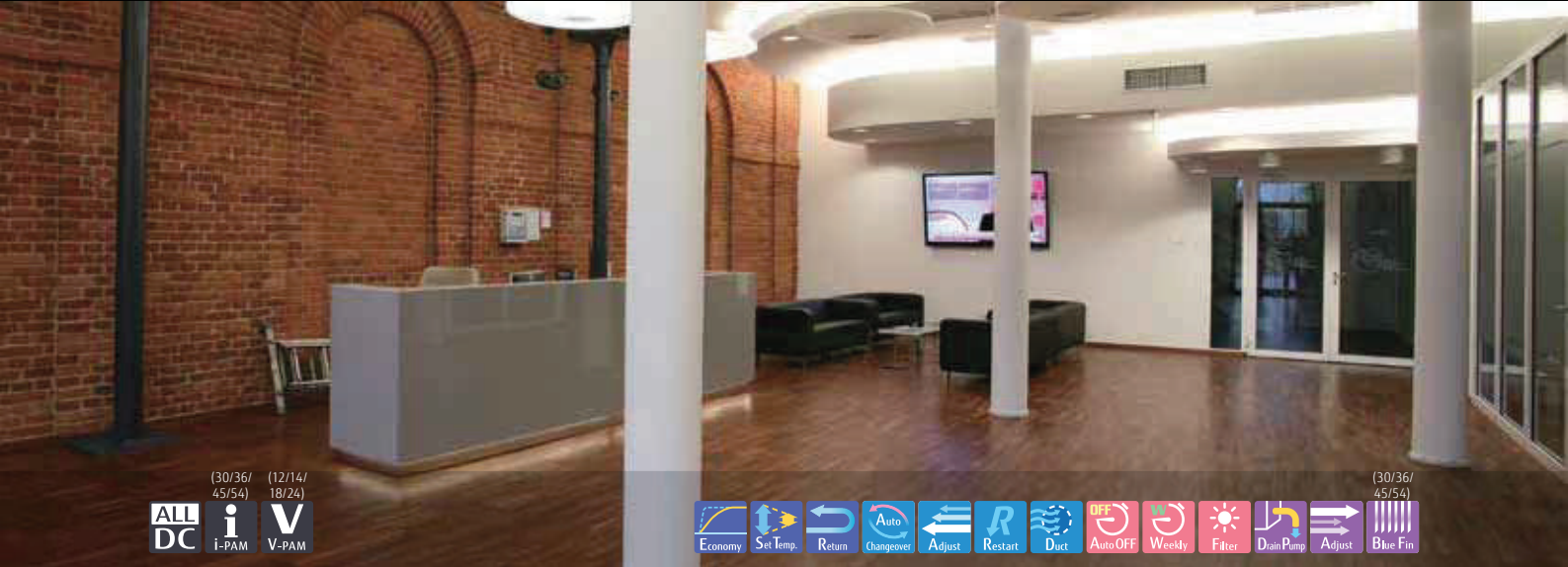

(30/36/45/54) (12/14/18/24)
ALL DC
 i-PAM V-PAM



Features

High Efficiency & Quiet operation

The combination of the V-shaped heat exchanger, air stabilizer, and the high efficient DC fan motor allowed high efficiency and quiet operation despite of the small structural design.

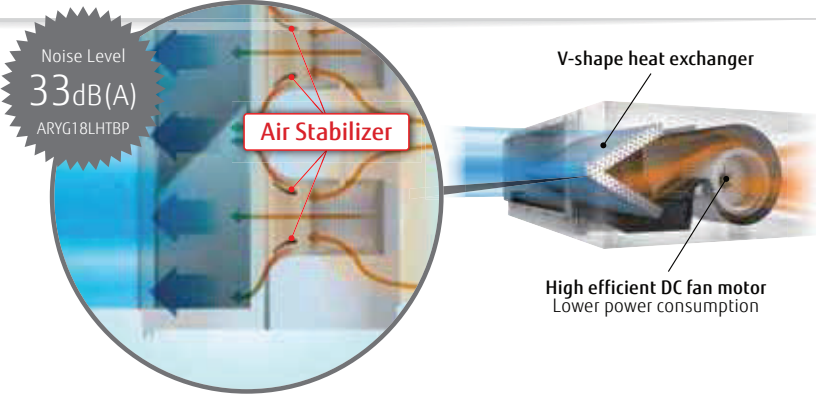

Automatic Airflow adjustment function

This unique and innovative function detects required air flow in each application case and automatically adjust the volume.



Improved installation flexibility

- Capable to be installed in various applications that requires static pressure of 30Pa to 200 Pa
- Built-in drain pump, rises drain up to 850 mm
- Unified depth throughout the range enables the selection of the capacity regardless of the additional space.

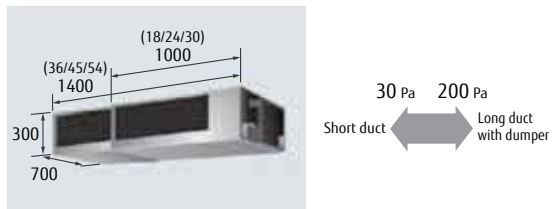

Improved service and maintenance

- Drain pump is easily detachable from the side
- Easy access to electrical box
- Error code can be checked more in detail from error history

Low ambient operation

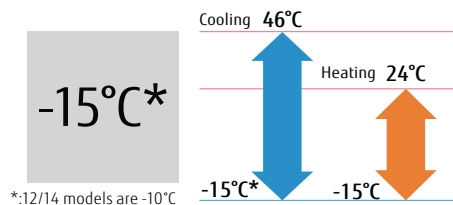

**Model: ARYG12LHTBP/ARYG14LHTBP, ARYG18LHTBP/ARYG24LHTBP
ARYG30LHTBP/ARYG36LHTBP/ARYG45LHTBP/ARYG54LHTBP**



Touch Panel Wired R.C.



ARYG12/14LHTBP



ARYG18/24/30LHTBP

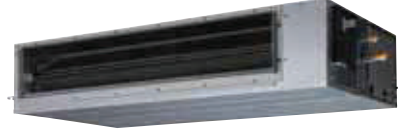

ARYG36/45/54LHTBP



For ARYG12/14/18/24LHTBP



For ARYG30/36LHTBP



For ARYG45/54LHTBP

Specifications

Model Number	Indoor	ARYG12LHTBP	ARYG14LHTBP	ARYG18LHTBP	ARYG24LHTBP	ARYG30LHTBP	ARYG36LHTBP	ARYG45LHTBP	ARYG54LHTBP
		AOYG12LBLA	AOYG14LBLA	AOYG18LBCA	AOYG24LBCA	ARYG30LBTB	ARYG36LBTB	ARYG45LBTB	ARYG54LBTB
Nominal Capacity (kW)	Cooling	3.5	4.3	5.2	6.8	8.5	9.4	12.1	13.4
	Heating	4.1	5.0	6.0	8.0	10.0	11.2	13.3	16.0
UK Total / Sensible Cooling*		tba	tba	4.57 / 3.37	5.98 / 4.84	8.59 / 6.84	9.03 / 7.38	11.31 / 9.40	12.89 / 10.42
Power Consumption (kW)	Cooling	0.90	1.18	1.37	1.95	2.65	2.83	3.59	4.42
	Heating	1.00	1.25	1.48	2.21	2.70	3.07	3.64	4.62
EER / COP (Nominal Conditions)		3.89/4.10	3.64/4.00	3.80/4.05	3.49/3.62	3.21/3.70	3.32/3.65	3.37/3.87	3.03/3.46
Pdesign (kW) @ -10°C	Cooling	3.5	4.3	5.2	6.8	8.5	9.4	-	-
	Heating	4.2	4.5	4.3	6.0	8.0	8.7	-	-
SEER	Cooling	6.20	4.3/4.5	7.15	6.50	5.95	5.81	-	-
SCOP	Heating (Average)	4.10	3.95	4.11	4.01	3.95	3.81	-	-
Energy Efficiency Class	Cooling	A++	A+	A++	A++	A+	A+	-	-
	Heating (Average)	A+	A	A+	A	A	A	-	-
Annual Energy Consumption (kWh/a)	Cooling	tba	tba	255	366	500	566	tba	tba
	Heating	tba	tba	1462	2092	2833	3194	tba	tba
Moisture Removal	l/h	tba	tba	1.2	1.8	2.3	2.0	2.6	3.7
Dimensions (HxWxD) mm	Inner	300x700x700	300x700x700	300x1000x700	300x1000x700	300x1000x700	300x1400x700	300x1400x700	300x1400x700
	Outer	578x790x300	578x790x300	620x790x290	620x790x290	830x900x330	830x900x330	1290x900x330	1290x900x330
Net Weight (kg)	Inner	27	27	36	36	36	46	46	46
	Outer	40	40	41	41	61	61	86	86
Room Air Circulation (high) m3/h	Inner	850	950	1050	1360	1700	2050	2550	2550
	Outer	1780	1910	1900	2460	3600	3800	6750	6750
Power Supply	V-PH-Hz	230-1-50	230-1-50	230-1-50	230-1-50	230-1-50	230-1-50	230-1-50	230-1-50
Power Supply To		Outdoor	Outdoor	Outdoor	Outdoor	Outdoor	Outdoor	Outdoor	Outdoor
Running Current (A)	Cooling	7.5	9.0	10.0	13.5	17.0	20.0	22.5	23.5
	Heating	10.0	12.5	13.5	18.5	17.0	20.0	22.5	23.5
Starting current	A	tba	tba	6.6	9.7	11.8	13.4	15.7	20.2
Suggested MCB/Fuse	A	15	15	15	20	20	25	25	25
Interconnecting Cable		3 + E	3 + E	3 + E	3 + E	3 + E	3 + E	3 + E	3 + E
Remote Control Type (supplied with indoor unit)		Wired	Wired	Wired	Wired	Wired	Wired	Wired	Wired
Static Pressure Range (standard)	Pa	30 to 200 (35)	30 to 200 (35)	30 to 200 (35)	30 to 200 (35)	30 to 200 (47)	30 to 200 (47)	30 to 200 (60)	30 to 200 (60)
Sound Pressure (dB(A) Cooling)	Indoor O/L/M/H	32/30/25/22	33/28/27/23	28/25/22/20	32/28/24/21	36/33/30/29	36/31/28/26	39/35/31/29	39/35/31/29
	Outdoor H	47	49	50	55	53	54	55	55
Sound Power (dB(A) Cooling)	Indoor H	tba	tba	54	57	63	64	67	67
	Outdoor H	61	62	63	68	68	69	68	69
Max Pipe Length	m	25	25	30	30	50	50	50	50
Max Height Difference	m	15	15	20	20	30	30	30	30
Refrigerant Charge	m	15	15	15	15	20	20	20	20
Additional Refrigerant Charge	g/m	tba	tba						
	Gas	3/8	1/2	1/2	5/8	5/8	5/8	5/8	5/8
Pipe Size (inches)	Liquid	1/4	1/4	1/4	3/8	3/8	3/8	3/8	3/8
	Cooling	-10 to 46	-10 to 46	-15 to 46	-15 to 46	-15 to 46	-15 to 46	-15 to 46	-15 to 46
Operating Range °CDB	Heating	-15 to 24	-15 to 24	-15 to 24	-15 to 24	-15 to 24	-15 to 24	-15 to 24	-15 to 24
	Refrigerant	R410A	R410A	R410A	R410A	R410A	R410A	R410A	R410A
Filter (to be ordered separately)		UTD-LFNC	UTD-LFNC	UTD-LFNB	UTD-LFNB	UTD-LFNB	UTD-LFNA	UTD-LFNA	UTD-LFNA
System List Price	£	Future Release	Future Release	1728	2267	2687	3263	3348	3507

Optional parts

Simple Remote Controller:	UTY-RSNYM	£80	Modbus Interface	FJRCMBS1	£225
IR Receiver Unit :	UTY-LBTYM	£256	KNX Interface	FJRCKNX1i	£255
External input and output PCB (with bracket):	UTY-XCSX + UTZ-GXNA	£82 + £27	WiFi Interface	FJRCWIF1	£225
External connect kit:	UTY-XWZXZG, UTY-XWZXZ3	£9, £9			
Long life filter:	UTD-LFNA (for ARYG36/45/54LHTBP)	£59			
	UTD-LFNB (for ARYG24/30LHTBP)	£59			
	UTD-LFNC (for ARYG12/14LHTBP)	£59			
Remote Sensor Unit:	UTY-XSZX	£54			

* UK Cooling: indoor temperature 23°CDB / 16°CWB and outdoor temperature 30°C

Dimensions

(Unit : mm)

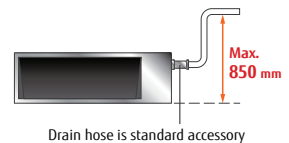
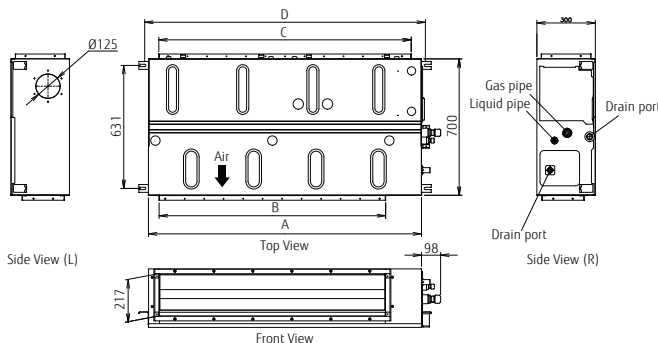

Drain hose is standard accessory

	ARYG12/14LHTBP	ARYG18/24/30LHTBP	ARYG36/45/54LHTBP
A	700	1,000	1,400
B	462	762	1,162
C	650	895	1,295
D	740	1,040	1,440

Medium Static Pressure Duct High Efficiency & Comfort

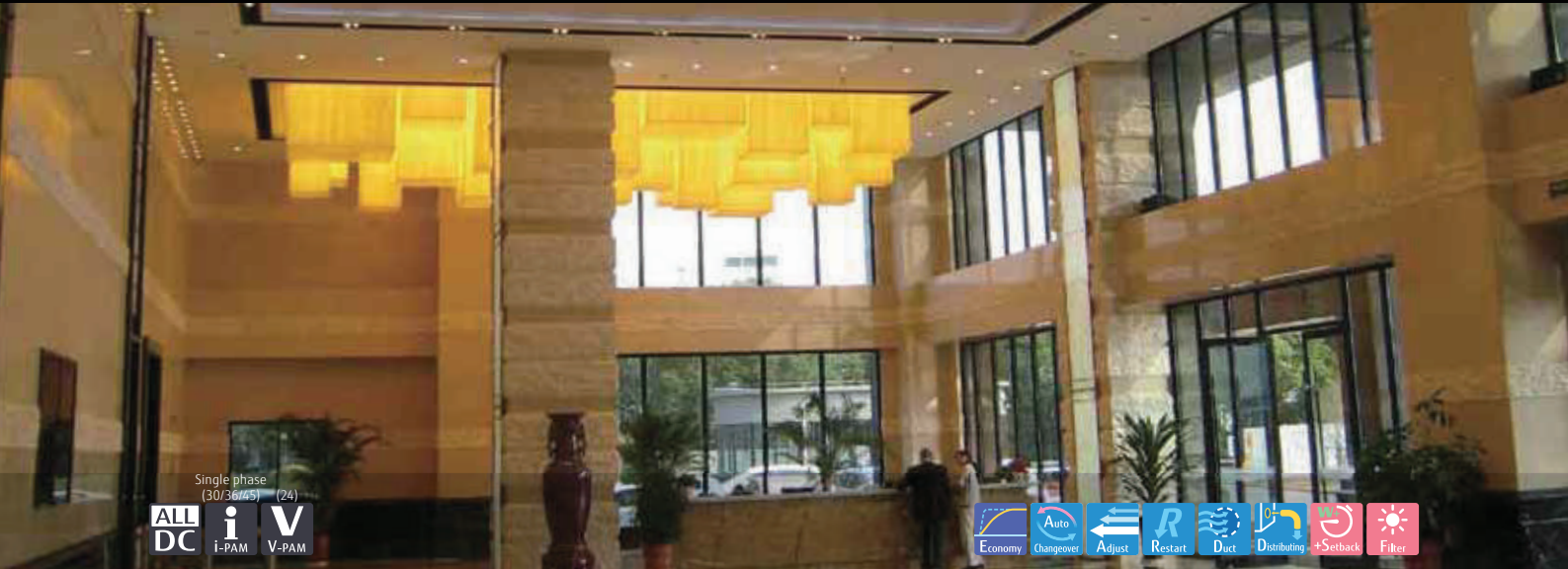

Features

Slim & Compact design

In the case of bottom return air connection, not only does the indoor unit design allow for installation in a narrow ceiling space of up to 270 mm, Further space savings have been achieved by mounting the control box internally inside the chassis.

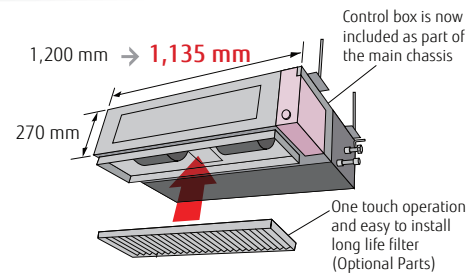

Two-direction drain piping

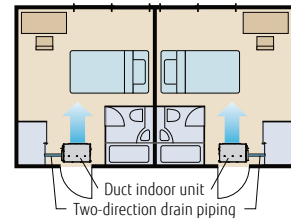

Easy maintenance

Structural improvement is attained by making the bottom panel two pieces, front and rear. The internal fan casing is also manufactured in two pieces, namely upper and lower. The maintenance of the motor and fan can be easily carried out by removing the rear panel and the lower part of the casing while leaving the main chassis installed.

See below for the case of rear suction type

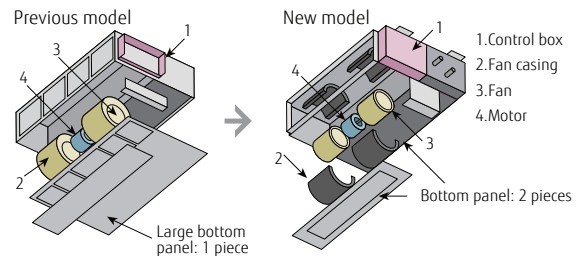

Low ambient operation

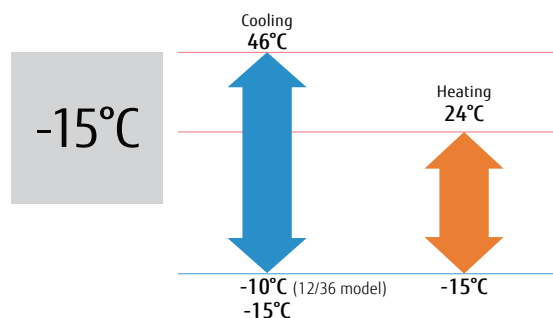

Model : ARYG24LMLA / ARYG30LMLA / ARYG36LMLA / ARYG45LMLA / ARYG36LMLA [3phase] / ARYG45LMLA [3phase]



Wired R.C.



For ARYG24LMLA



For ARYG30/36LMLA



For ARYG36/45LMLA

Specifications

	Indoor	3-Phase Units					
		ARYG24LMLA AOYG24LALA	ARYG30LMLA AOYG30LETL	ARYG36LMLA AOYG36LETL	ARYG45LMLA AOYG45LETL	ARYG36LMLA AOYG36LATT	ARYG45LMLA AOYG45LATT
Nominal Capacity (kW)	Cooling Heating	6.80 (0.90-8.00) 8.00 (0.90-9.10)	8.50 (2.80-10.00) 10.00 (2.70-11.20)	9.40 (2.80-11.20) 11.20 (2.70-12.70)	12.10 (4.00-13.30) 13.30 (4.20-15.50)	10.00 (4.70-11.40) 11.20 (5.00-14.00)	12.50 (5.00-14.00) 14.00 (5.40-16.20)
UK Total / Sensible Cooling *		5.98 / 4.52	8.41 / 6.66	9.03 / 6.72	11.31 / 8.53	9.07 / 6.39	11.38 / 7.69
Power Consumption (kW)	Cooling Heating	2.21 2.26	2.65 2.68	2.96 3.10	3.77 3.68	2.84 2.87	3.89 3.88
EER / COP (Nominal Conditions)		3.08 / 3.54	3.21 / 3.73	3.18 / 3.61	3.21 / 3.61	3.52 / 3.90	3.21 / 3.61
Pdesign (kW) @ -10°C	Cooling Heating	6.80 6.00	8.50 8.00	9.40 8.70	- -	10.00 10.00	- -
SEER	Cooling	6.20	5.90	5.70	-	5.80	-
SCOP	Heating (Average)	4.00	3.90	3.80	-	4.00	-
Energy Efficiency Class	Cooling Heating (Average)	A++ A+	A+ A	A+ A	- -	A+ A+	- -
Annual Energy Consumption (kWh/a)	Cooling Heating	384 2098	504 2868	576 3202	- -	603 3497	- -
Moisture Removal	l/h	2.50	2.50	3.00	4.00	3.00	4.50
Dimensions (HxWxD) mm	Inner Outer	270x1135x700 578x790x315	270x1135x700 830x900x330	270x1135x700 830x900x330	270x1135x700 1290x900x330	270x1135x700 1290x900x330	270x1135x700 1290x900x330
Net Weight (kg)	Inner Outer	38 44	40 61	40 61	40 86	40 104	40 104
Room Air Circulation (high) m ³ /h	Inner Outer	1100 2470	1900 3600	1900 3800	2100 6200	1800 6200	2100 6750
Static Pressure Range (Standard)	Pa	30 to 150 (35)	30 to 150 (47)	30 to 150 (47)	30 to 150 (60)	30 to 150 (47)	30 to 150 (60)
Power Supply	V-PH-Hz	230 / 1 / 50	230 / 1 / 50	230 / 1 / 50	230 / 1 / 50	400 / 3 / 50	400 / 3 / 50
Power Supply To	Outdoor	Outdoor	Outdoor	Outdoor	Outdoor	Outdoor	Outdoor
Running Current (A)	Cooling Heating	9.70 9.90	11.60 11.70	13.00 13.60	16.50 16.10	4.30 4.40	5.80 5.80
Starting Current	A	9.90	12.20	13.70	22.50	10.00	10.00
Suggested MCB/Fuse	A	16	20	25	25	16	16
Interconnecting Cable		3 + E	3 + E	3 + E	3 + E	3 + E	3 + E
Remote Control Type		Wired	Wired	Wired	Wired	Wired	Wired
Sound Pressure (dB(A) Cooling)	Indoor Q/L/M/H Outdoor H	25 / 27 / 29 / 31 52	26 / 30 / 35 / 39 53	26 / 30 / 35 / 39 54	28 / 32 / 38 / 42 55	26 / 31 / 36 / 38 51	28 / 32 / 38 / 42 54
Sound Power (dB(A) Cooling)	Indoor H Outdoor H	60 67	65 68	65 69	- -	65 67	- -
Max Pipe Length	m	30	50	50	50	75	75
Max Height Difference	m	20	30	30	30	30	30
Refrigerant Charge	m	15	20	20	20	30	30
Additional Refrigerant Charge	g/m	20	40	40	40	50	50
Pipe Size (inches)	Gas Liquid	5/8 1/4	5/8 3/8	5/8 3/8	5/8 3/8	5/8 3/8	5/8 3/8
Operating Range (OC)	Cooling Heating	-10 ~ 46 -15 ~ 24	-15 ~ 46 -15 ~ 24	-15 ~ 46 -15 ~ 24	-15 ~ 46 -15 ~ 24	-15 ~ 46 -15 ~ 24	-15 ~ 46 -15 ~ 24
Refrigerant		R410A	R410A	R410A	R410A	R410A	R410A
System List Price	£	1916	2372	2559	2884	2771	3024

Optional parts

Wired Remote Controller:	UTYRVNYM	£100	Drain Pump Unit:	UTZPX1NBA	£60
Simple Remote Controller:	UTYRSNYM	£80	IR Reciever Kit:	UTYLRHYM	£252
Flange (Round)	UTDRF204	£30	External Connect Kit	UTDECS5A	£13
Flange (Square)	UTDSF045T	£40	Modbus Interface	FJRCMBS1	£225
Long Life Filter	UTDLF25NA	£91	KNX Interface	FJRCNX1i	£255
Remote Sensor Unit	UTYXSZX	£54	WiFi Interface	FJRCWIF1	£225

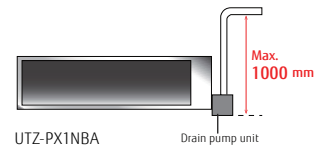

Dimensions

(Unit : mm)

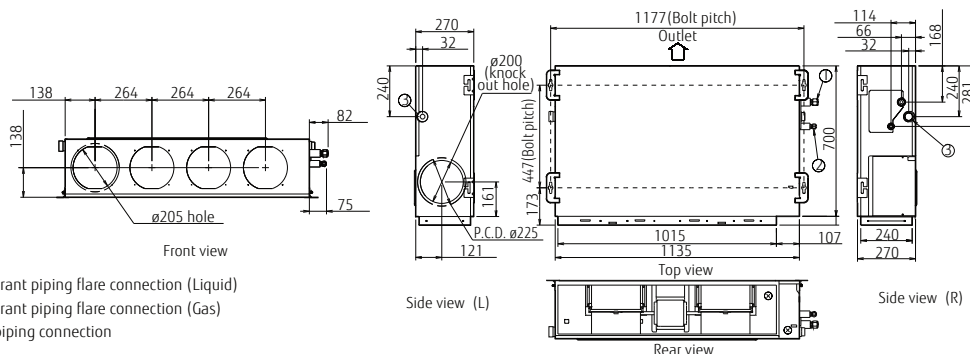

- ① Refrigerant piping flare connection (Liquid)
- ② Refrigerant piping flare connection (Gas)
- ③ Drain piping connection

* UK Cooling: indoor temperature 23°CDB / 16°CWB and outdoor temperature 30°C

High Static Pressure Duct



Features

High energy efficiency

Significantly greater efficiency is realized by using all DC inverter technology. (60 type)

Design also corresponding to high static pressure

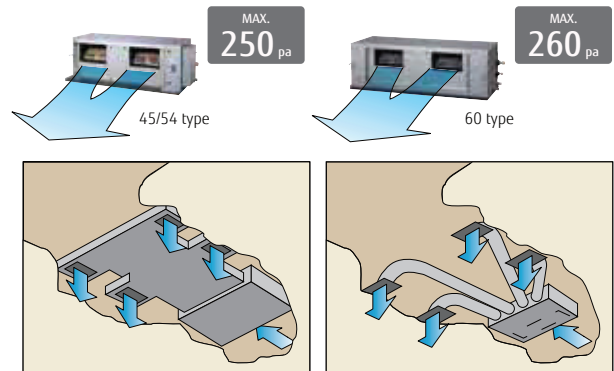

Easy installation (Compact size & Lightweight)

A compact size and lightweight indoor unit has been developed by reducing the basic chassis and the overall material weight.

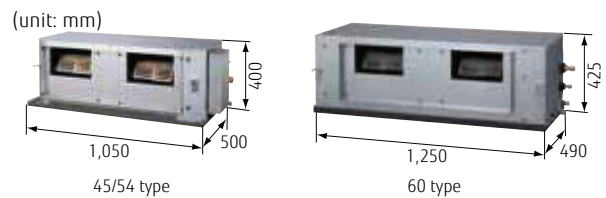

Low noise

Cutting off the corners has enabled less turbulent airflow. Low noise is realized by adopting a plastic case and a plastic fan.

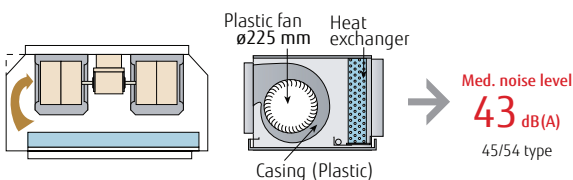

Low ambient operation

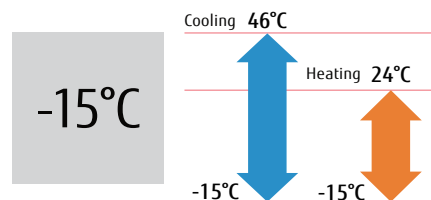

**Model : ARYG45LHTA / ARYG54LHTA /
ARYG45LHTA [3phase] / ARYG54LHTA [3phase] / ARYG60LHTA [3phase]**



Wired R.C.



ARYG45/54LHTA



ARYG60LHTA



Specifications

	Indoor Outdoor	3-Phase Units		
		ARYG45LHTA AOYG45LETL	ARYG54LHTA AOYG54LETL	ARYG60LHTA AOYG60LATT
Nominal Capacity (kW)	Cooling Heating	12.50 (4.50-14.00) 14.00 (5.00-16.20)	13.40 (5.00-14.50) 16.00 (5.50-18.00)	12.50 (5.00-14.00) 14.00 (5.40-16.00) 15.00 (6.20-17.50) 18.00 (6.20-20.00)
UK Total / Sensible Cooling *		12.07 / 10.17	13.14 / 10.93	11.47 / 9.59
Power Consumption (kW)	Cooling Heating	4.30 3.80	4.77 4.69	4.06 3.67
EER / COP (Nominal Conditions)		2.91 / 3.68	2.81 / 3.41	3.08 / 3.81
Pdesign (kW) @ -10°C	Cooling Heating	- -	- -	- -
SEER	Cooling	-	-	-
SCOP	Heating (Average)	-	-	-
Energy Efficiency Class	Cooling Heating (Average)	- -	- -	- -
Annual Energy Consumption (kWh/a)	Cooling Heating	- -	- -	- -
Moisture Removal	l/h	1.50	2.00	1.50
Dimensions (HxWxD) mm	Inner Outer	400x1050x500 1290x900x330	400x1050x500 1290x900x330	400x1050x500 1290x900x330
Net Weight (kg)	Inner Outer	46 86	46 86	46 104
Room Air Circulation (high) m ³ /h	Inner Outer	3350 6750	3350 6750	3350 6900
Static Pressure Range (Standard)	Pa	100 to 250 (100)	100 to 250 (100)	100 to 250 (100)
Power Supply	V-PH-Hz	230 / 1 / 50	230 / 1 / 50	400 / 3 / 50
Power Supply To	Outdoor	Outdoor	Outdoor	Outdoor
Running Current (A)	Cooling Heating	18.90 16.70	20.90 20.50	6.10 5.50
Starting Current	A	22.50	23.50	10.00
Suggested MCB/Fuse	A	25	25	16
Interconnecting Cable		3 + E	3 + E	3 + E
Remote Control Type		Wired	Wired	Wired
Sound Pressure (dB(A) Cooling)	Indoor Q/L/M/H Outdoor H	- / 40 / 43 / 47 55	- / 40 / 43 / 47 55	- / 40 / 43 / 47 54
Sound Power (dB(A) Cooling)	Indoor H Outdoor H	- -	- -	- -
Max Pipe Length	m	50	50	75
Max Height Difference	m	30	30	30
Refrigerant Charge	m	20	20	30
Additional Refrigerant Charge	g/m	40	40	50
Pipe Size (inches)	Gas Liquid	5/8 3/8	5/8 3/8	5/8 3/8
Operating Range (OC)	Cooling Heating	-15 ~ 46 -15 ~ 24	-15 ~ 46 -15 ~ 24	-15 ~ 46 -15 ~ 24
Refrigerant		R410A	R410A	R410A
System List Price	£	2942	3166	3082

Optional parts

Wired Remote Controller:	UTYRVNYM	£100	External Connect Kit - Indoor	UTDECS5A	£13
Simple Remote Controller:	UTYRSNYM	£80	External Connect Kit - Outdoor	UTYXWZXZ2	£18
Long Life Filter	UTDLF60KA (for ARYG45/54LHTA only)	£91	Modbus Interface	FJRCMBS1	£225
Remote Sensor Unit:	UTYXSZX	£54	KNX Interface	FJRCKNX1i	£255
IR Receiver Kit	UTYLRHYM (for ARYG60LHTA only)	£252	WiFi Interface	FJRCWIF1	£225

Dimensions

(Unit : mm)

Model: ARYG45LHTA / ARYG54LHTA

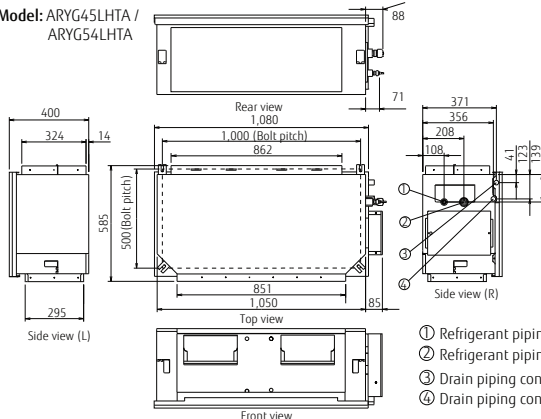

Model: ARYG60LHTA

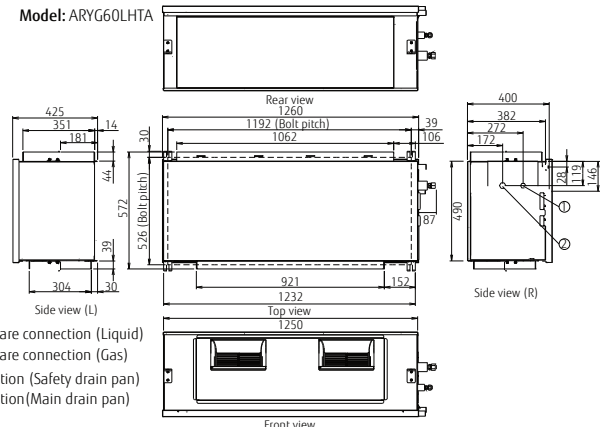

- ① Refrigerant piping flare connection (Liquid)
- ② Refrigerant piping flare connection (Gas)
- ③ Drain piping connection (Safety drain pan)
- ④ Drain piping connection (Main drain pan)

High Static Pressure Duct



ALL DC



Features

High energy efficiency

Significantly greater efficiency is realized by using DC twin rotary compressor, all DC inverter technology, and large heat exchanger.

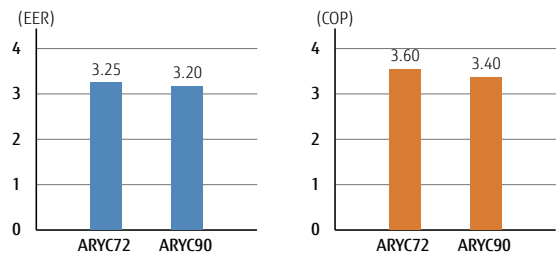

5 Static Pressure selection

Improvement and design flexibility has allowed multiple fan speeds and static pressure modes. Low noise is realized by adopting plastic case, plastic fan.

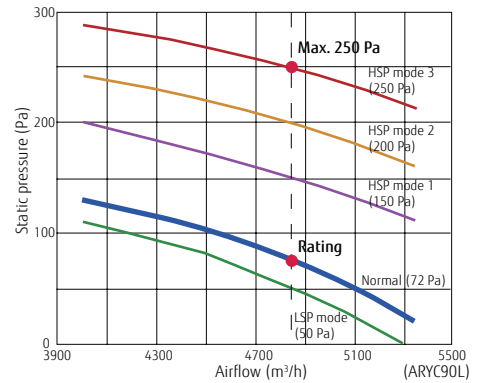

Outdoor unit quiet operation

A low outdoor noise operation mode allows the outdoor unit to have two quiet mode operation settings.

Peak cut operation

A peak power consumption mode controls a 4 step outdoor operation control to cut down energy usage at peak energy usage times.

Low ambient operation

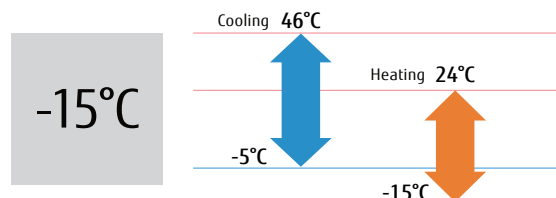

Model : ARYC72LHTA [3phase] / ARYC90LHTA [3phase]



Wired R.C.



ARYC72LHTA



ARYC90LHTA



Specifications

	Indoor	3-Phase Units	
		ARYC72LHTA AOYA72LALT	ARYC90LHTA AOYA90LALT
Nominal Capacity (kW)	Cooling	20.30 (10.80-23.50)	25.00 (11.20-28.00)
	Heating	22.60 (12.00-26.50)	28.00 (12.50-31.50)
UK Total / Sensible Cooling *		19.46 / 15.22	24.33 / 19.78
Power Consumption (kW)	Cooling	6.25	7.82
	Heating	6.27	8.24
EER / COP (Nominal Conditions)		3.25 / 3.60	3.20 / 3.40
Pdesign (kW) @ -10°C	Cooling	-	-
	Heating	-	-
SEER	Cooling	-	-
SCOP	Heating (Average)	-	-
Energy Efficiency Class	Cooling	-	-
	Heating (Average)	-	-
Annual Energy Consumption (kWh/a)	Cooling	-	-
	Heating	-	-
Moisture Removal	l/h	4.50	6.00
Dimensions (HxWxD) mm	Inner	450x1587x700	550x1587x700
	Outer	1690x930x765	1690x930x765
Net Weight (kg)	Inner	100	110
	Outer	215	215
Room Air Circulation (high) m3/h	Inner	4300	4850
	Outer	9300	10700
Power Supply	V-PH-Hz	400 / 3 / 50	400 / 3 / 50
Power Supply To		Outdoor	Outdoor
Running Current (A)	Cooling	9.60	11.90
	Heating	9.60	12.50
Static Pressure Range (Standard)	Pa	50 to 250 (72)	50 to 250 (72)
Starting Current	A	9.60	12.50
Suggested MCB/Fuse	A	25	30
Interconnecting Cable		3 + E	3 + E
Remote Control Type		Wired	Wired
Sound Pressure (dB(A) Cooling)	Indoor Q/L/M/H	- / 41 / 44 / 47	- / 43 / 46 / 49
	Outdoor H	57	58
Sound Power (dB(A) Cooling)	Indoor H	-	-
	Outdoor H	-	-
Max Pipe Length	m	75	75
Max Height Difference	m	30	30
Refrigerant Charge	m	20	20
Additional Refrigerant Charge	g/m	110	110
Pipe Size (inches)	Gas	7/8	7/8
	Liquid	1/2	1/2
Operating Range (OC)	Cooling	-5 ~ 46	-5 ~ 46
	Heating	-15 ~ 24	-15 ~ 24
Refrigerant		R410A	R410A
System List Price	£	5103	5614

Optional parts

Wired Remote Controller:	UTYRVNYM	£100
Simple Remote Controller:	UTYRSNYM	£80
Remote Sensor Unit:	UTYXSZX	£54
External Connect Kit - Indoor	UTDECS5A	£13
External Connect Kit - Outdoor	UTYXWZXZ2	£18
Modbus Interface	FJRCMBS1	£225
KNX Interface	FJRCKNX1i	£255
WiFi Interface	FJRCWIFI1	£225

* UK Cooling: indoor temperature 23°CDB / 16°CWB and outdoor temperature 30°C

Dimensions

(Unit : mm)

Model: ARYC72LHTA

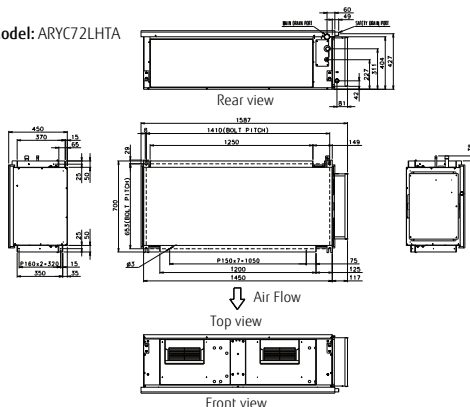

Model: ARYC90LHTA

